



CX20702 Features CODEC

- 4-wire and 5-wire digital audio I/O (I²S/PCM/SPDIF), supporting full duplex independent sampling rates
- One 3-wire I²C or 4-wire SPI slave interface for external MCU
- USB 2.0 Compliant Audio Class Interface
- Integrated PWM output, re-taskable as differential line out
- Eight GPIO pins
- Spread Spectrum for filter-less, low EMI output
- Three single-ended line in (convertible to one stereo differential line in and one single-end)
- Two microphones interfaces with on-chip bias supply
- Integrated 50 mW headphone driver with jack sense
- Differential line out
- 24-bit DAC/ADC, SNR 102 dB, THD - 92 dB at 48 kHz 3.3 V
- Audio sample rate: 8, 11.025, 12, 16, 22.05, 24, 32, 44.1, 48, 64, 88.2, 96 kHz
- 90 dB dynamic range with 0.01percent THD+N at 4 Ω load
- 10-bit ADC multiplexed to support analog volume potentiometer and DC level detection

- Flexible power management
- Variable master clock rates
 - 7 mW stereo playback (1.8V supply)
 - 14 mW record and playback (1.8V supply)

DSP

- Subband acoustic echo suppression and cancellation
- Array mic beam-forming
- Noise reduction
- Dynamic loudness adaptor
- Mic auto gain control
- Digital parametric equalizer (10 bands/channel)
- Dynamic range compression
- Digital Crossover
- 3D Expander (Phantom mode and Immersion mode)

SPoC Configuration Toolbox

- Fast configuration tool via USB-to-I²C from PC
- Device configuration and DSP parameter adjustment
- Output log for convenient MCU programming

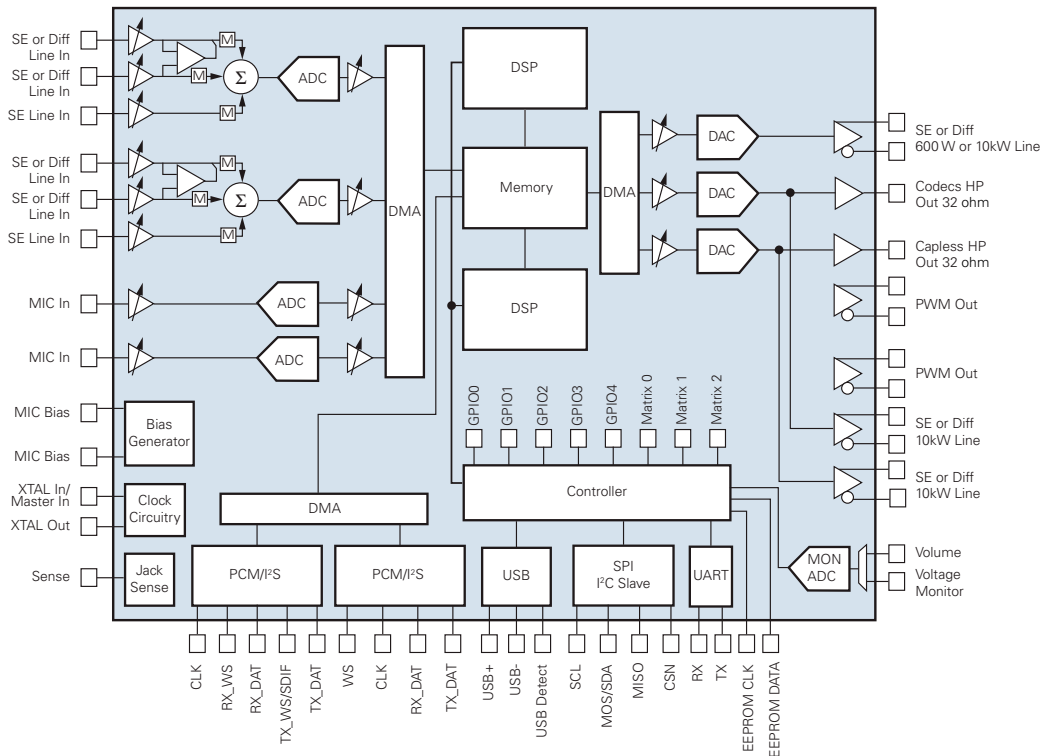

CX20702 Interface Diagram
The CX20702 is offered in a 76-pin QFN package

Conexant Product Portfolio

Conexant's comprehensive product portfolio includes solutions for imaging, audio, embedded modem and video surveillance applications.

© 2009 Conexant Systems, Inc. All Rights Reserved. Conexant and the Conexant logo are registered trademarks of Conexant Systems, Inc. All other trademarks are owned by their respective owners. Although Conexant strives for accuracy in all its publications, this material may contain errors or omissions and is subject to change without notice. **THIS MATERIAL IS PROVIDED AS IS AND WITHOUT ANY EXPRESS OR IMPLIED WARRANTIES, INCLUDING MERCHANTABILITY, FITNESS FOR A PARTICULAR PURPOSE AND NON-INFRINGEMENT.** Conexant shall not be liable for any special, indirect, incidental or consequential damages as a result of its use.

www.conexant.com
General Information:
U.S. and Canada: (888) 855-4562
International: 1+ (949) 483-3000
Headquarters
4000 MacArthur Blvd.
Newport Beach, CA 92660
Doc# PBR-202390

