





**CX20709 Features**  
**CODEC**

- 4-wire and 5-wire digital audio I/O (I<sup>2</sup>S/PCM/SPDIF), supporting full duplex independent sampling rates
- One 3-wire I<sup>2</sup>C or 4-wire SPI slave interface for external MCU
- Eight GPIO pins
- 2.5 W x 2 BTL stereo Class-D speaker amplifier, also configurable as a PWM output for external feedback-less type Class-D amplifier
- USB 2.0 Compliant Audio Class Interface (high speed data and control)
- Output for external feedback-less type Class-D amplifier
- Spread Spectrum for filter-less, low EMI output
- Three single-ended stereo or one differential stereo analog audio input converted to digital format
- Two microphones interfaces with on-chip bias supply
- Integrated 50 mW headphone driver with jack sense
- Differential line out
- Separately mixed mono line-output
- Three 24-bit DAC/four ADC, SNR 102 dB, THD - 92 dB at 48 kHz 3.3 V
- Audio sample rate: 8, 11.025, 12, 16, 22.05, 24, 32, 44.1, 48, 64, 88.2, 96 kHz

- 90 dB dynamic range with 0.01percent THD+N at 4 Ω load
- 10-bit ADC multiplexed to support analog volume potentiometer and DC level detection
- Flexible power management
- Variable master clock rates

**DSP**

- Subband acoustic echo suppression and cancellation
- Stereo beam-forming
- Noise reduction
- Dynamic loudness adaptor
- Mic auto gain control
- Subband line echo cancellation (two-way intercom applications)
- Digital parametric equalizer (10 bands/channel)
- Dynamic range compression
- 4th Order Digital Crossover for Subwoofer Line-out
- 3D Expander (Phantom mode and Immersion mode)

**SPoC Configuration Toolbox**

- Fast configuration tool via USB-to-I<sup>2</sup>C from PC
- Device configuration and DSP parameter adjustment
- Output log for convenient MCU programming

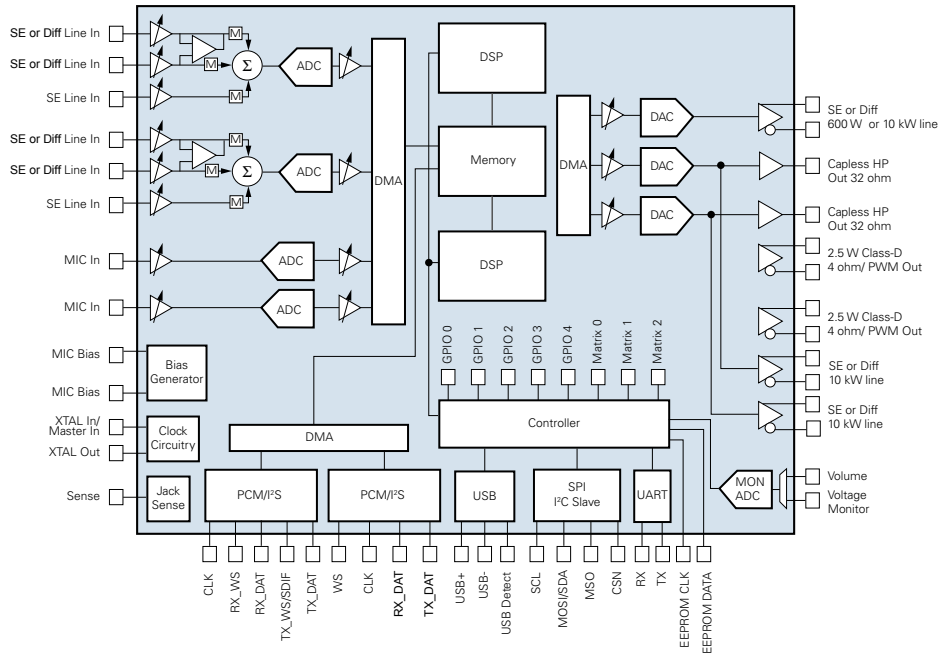

**CX20709 Interface Diagram**  
The CX20709 is offered in a 76-pin QFN package

**Conexant Product Portfolio**

Conexant's comprehensive product portfolio includes solutions for imaging, audio, embedded modem and video surveillance applications.

© 2009 Conexant Systems, Inc. All Rights Reserved. Conexant and the Conexant logo are registered trademarks of Conexant Systems, Inc. All other trademarks are owned by their respective owners. Although Conexant strives for accuracy in all its publications, this material may contain errors or omissions and is subject to change without notice. **THIS MATERIAL IS PROVIDED AS IS AND WITHOUT ANY EXPRESS OR IMPLIED WARRANTIES, INCLUDING MERCHANTABILITY, FITNESS FOR A PARTICULAR PURPOSE AND NON-INFRINGEMENT.** Conexant shall not be liable for any special, indirect, incidental or consequential damages as a result of its use.

**www.conexant.com**  
General Information:  
U.S. and Canada: (888) 855-4562  
International: 1+ (949) 483-3000  
Headquarters  
4000 MacArthur Blvd.  
Newport Beach, CA 92660  
Doc# PBR-202391

